

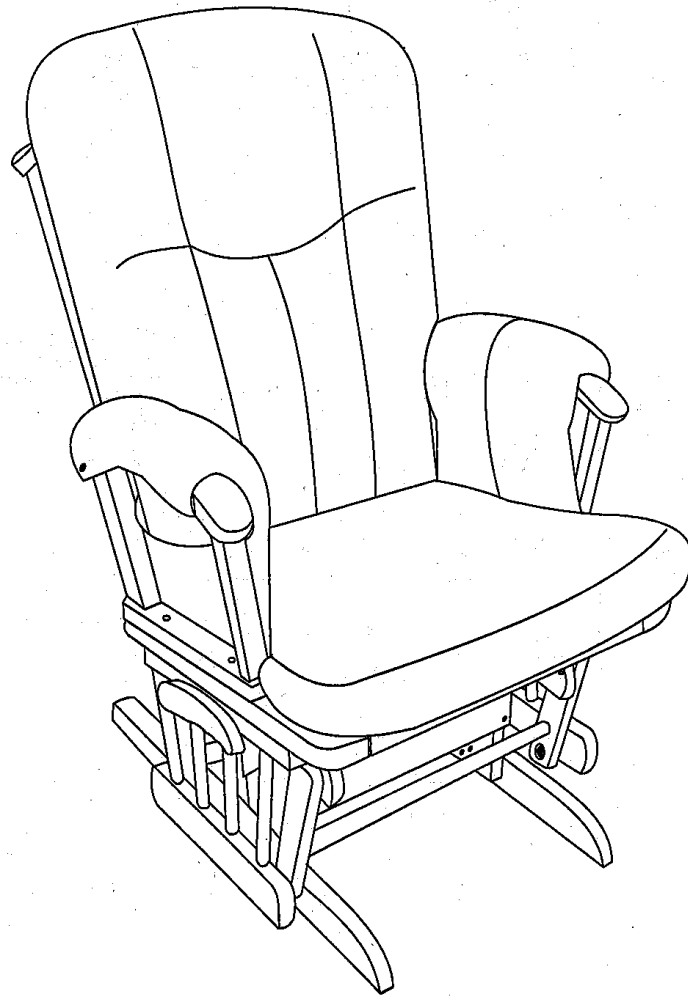







ASSEMBLY INSTRUCTION



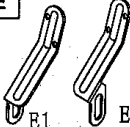
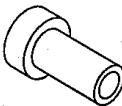
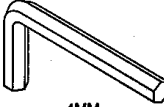

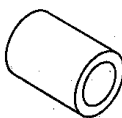

DELUXE GLIDER/RECLINER

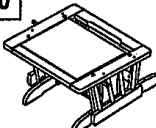

HARDWARE LIST

A  1/4" DIA X 3/4"	B  1/4" X 1/2"	C  1/4" DIA X 1-1/2"	D  5/16" DIA X 2"	E  E1 E2 IRON PLATE 2PCS
F  5/8" X 1-5/16"	G  4MM	H  3/16" DIA X 3/4"	W  3/16" X 5/16"	M  5/8" X 7/8"
F NYLON BUSHING 2PCS	G ALLEN KEY 1PC	H HEX SOCKET HEAD BOLT 2PCS	W SMALL SPRING WASHER 2PCS	M NYLON BUSHING 2PCS
N  11/16" X 3/4" NYLON BUSHING 1PC				

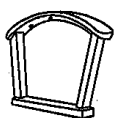
PARTS LIST

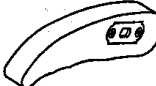
10  BASE 1PC	20  BACK FRAME 1PC	30S  SEAT CUSHION 1PC	30B  BACK CUSHION 1PC	35  ARM CUSHION 2PCS	
40L  LEFT ARM ASSEMBLY 1PC	40R  RIGHT ARM ASSEMBLY 1PC	50L  LEFT HANDLE 1PC	50R  RIGHT HANDLE 1PC		

STEP 1

1. Attach the left handle (50L) to the iron tube on the base by using hex socket head bolt (H), spring washer (W) and Allen Key (G) as shown in details 1.

2. Attach the right handle (50R) to the iron tube on the base by using hex socket head bolt (H), spring washer (W), nylon bushing (N) and Allen Key (G) as shown in detail 2.

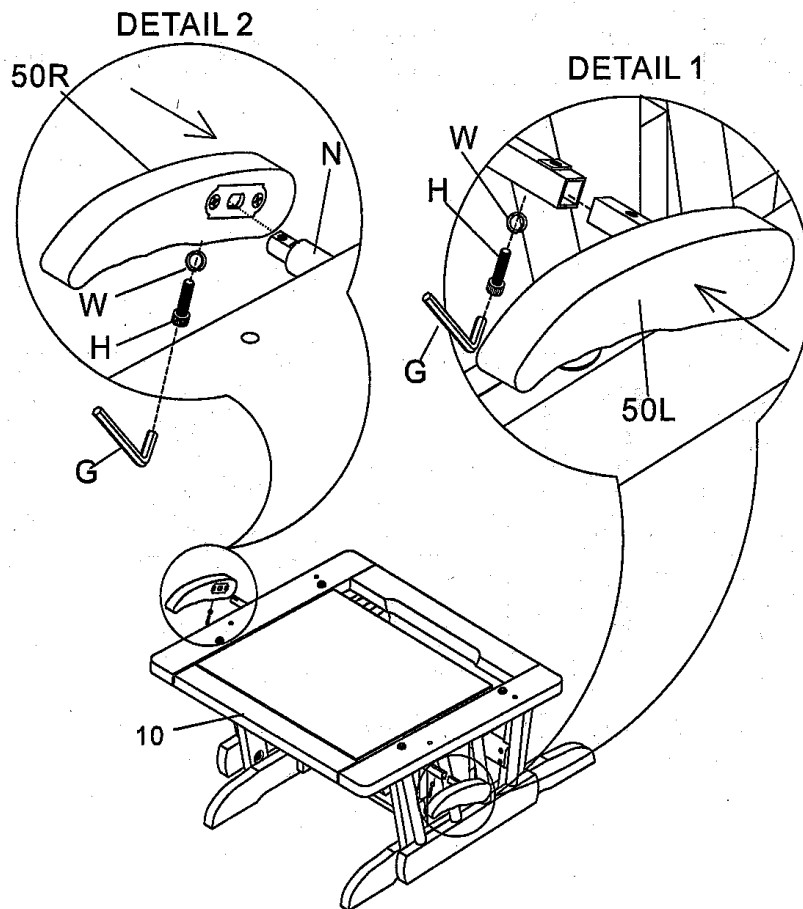

STEP 2

1. Attach right and left arm assemblies (40R & 40L) to the base (10) using hex socket head bolts (C) and large spring washer (B). Use Allen Key (G) to fasten bolts as shown in detail A.

NOTE: DO NOT fully tighten bolts. Leave them loose enough so that the arms move freely.

2. Attach the back frame (20) to the arm assemblies (40R & 40L) using the nylon bushings (F) and bolts (D). Use Allen Key (G) to tighten bolts (D).

3. Place iron plates (E1) and (E2) in the appropriate positions as shown in detail C. Attach the iron plates (E1) and (E2) to the back frame (20) using hex socket head bolts (A), large spring washers (B) and Allen Key (G). Be sure to insert nylon bushings (M) onto metal rods located on base (10) before inserting iron plates (E1) and (E2).

4. Fully tighten all bolts installed in previous steps.

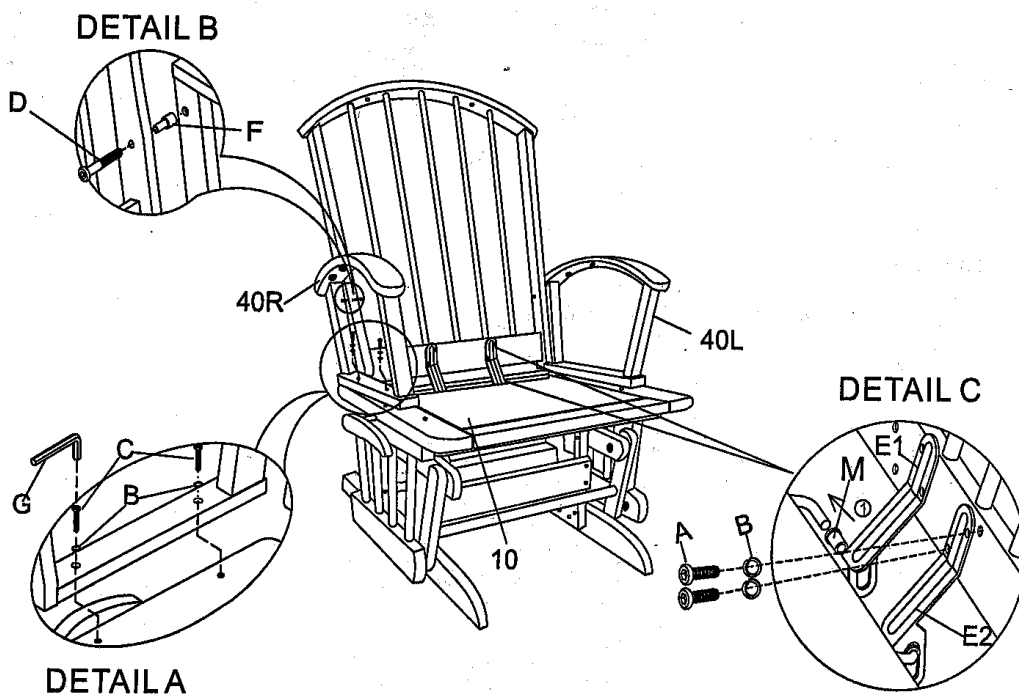

STEP 3

Attach the armrest cushions (35) to the armrests by buttoning the snaps along the interior seat and on the sides as shown.

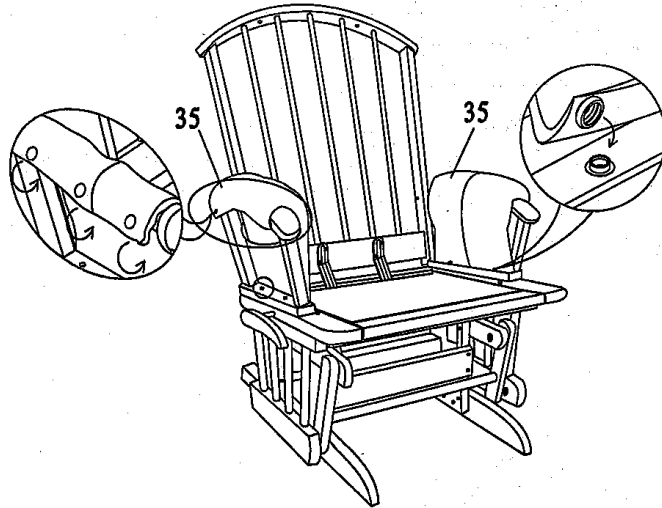

STEP 4

Attach the seat cushion (30S) to the back frame (20).

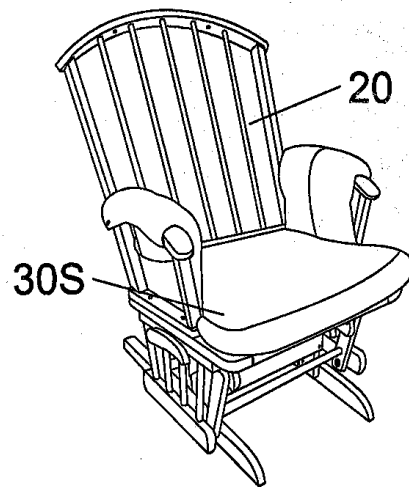

STEP 5

Attach the back cushion (30B) to the back frame (20).

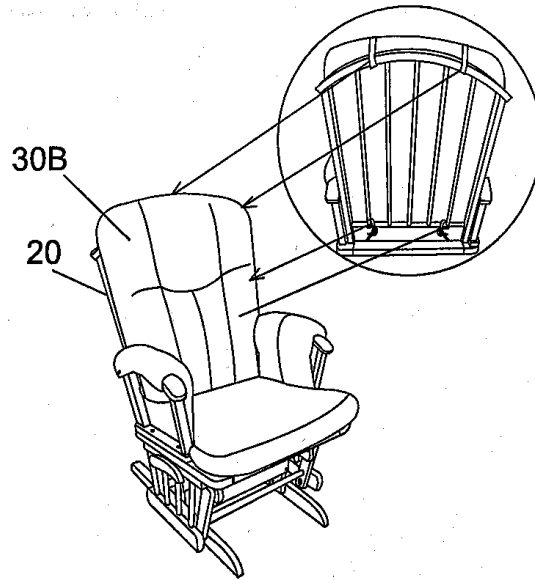

**NOTE: Use left handle (50L) to release or activate the gliding function.
Use right handle (50R) to release or activate the reclining function.**

